

VTA

Variable turbine area

Engineering the Future – since 1758.

MAN Diesel & Turbo



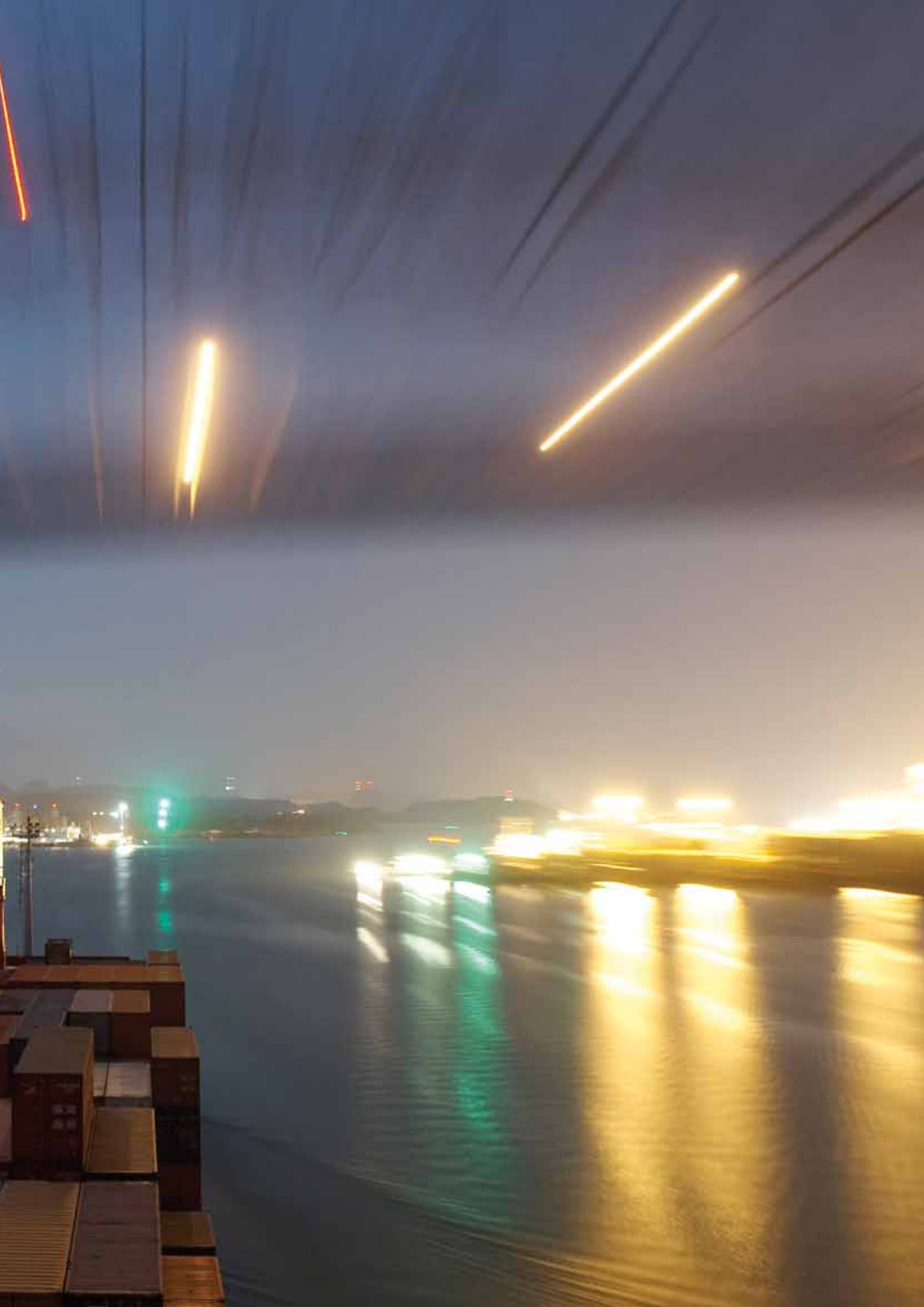

MAN Diesel & Turbo

The responsible way in leading technology

MAN Diesel & Turbo is the world's leading designer and manufacturer of large exhaust gas turbochargers for low and medium speed diesel and gas engines.

As an integral part of a leading developer and builder of two- and four-stroke, low and medium speed engines, the MAN Diesel & Turbo business unit turbocharger has a deep understanding of all the core technologies of large engines and their interaction with, the turbocharger.

The result is world and market leading turbocharger technology.

More than ever before, the development focus at the MAN Diesel & Turbo business unit turbocharger is the environmental performance of low and medium speed diesel and gas engines. The contribution of high efficiency exhaust gas turbochargers to this goal has been – and will continue to be – considerable.

MAN Diesel and Turbo's absolute commitment to reducing emissions while increasing fuel efficiency and power density starts with our active partnership in the emissions law making process and ends with the delivery of turbochargers that achieve an ideal synthesis of product characteristics.



Benefits of VTA

- Up to 4g/kWh lower fuel consumption
- Lower soot and smoke emission
- Lower CO₂ emissions
- Lower particle emissions
- Suitable for TCA and TCR turbochargers
- Retrofit packages
- Short payback time
- VTA cuts fuel consumption and reduces emissions



VTA – Variable Turbocharging

For large engines

Innovative benefits

Radial turbochargers featuring adjustable nozzle vanes ahead of the turbine to vary charge air output are in wide use on automotive diesel engines.

MAN Diesel & Turbo has taken up the challenge of transferring this technology to large turbochargers with both axial and radial turbines for installation on large diesel engines burning heavy fuel oil (HFO), probably the most difficult engine fuel in daily use.

MAN Diesel & Turbo's solution is the VTA "variable turbine area" technology and is now offered on its complete ranges of radial TCR and axial TCA turbochargers.

Up-to-date benefits

Due to high prices ship owners and operators are looking at ways of reducing fuel consumption. An immediately available solution is reducing vessel speed or "slow steaming".

To gain the full benefits of slow steaming, air management must be optimised by modifications to the turbocharging system.

Among various options retrofitting with VTA technology is the best – and most scientific – solution:

Turbocharger cut-off:

On engines with three or more turbochargers one turbocharger can be taken offline.

- With cut-off turbocharger only 66% load is available

Sequential turbocharging:

A second turbocharger of different size can be added to the engine. Control flaps cut the smaller turbocharger in or out according to engine load.

VTA technology provides entirely new turbocharging possibilities on large diesel engines.

Flexible air and fuel management are key factors in meeting both the emission legislation of the future and the expectations of operators in terms of engine performance and specific fuel oil consumption (SFOC).

Using the VTA system, the volume of charge air can be precisely matched to the quantity of injected fuel at all points in an engine's load and speed range. The result is reduced specific fuel consumption, reduced emissions HC and CO₂ and improved engine response.

- Extensive retrofit work required
- Compromises turbocharger efficiency over the complete engine load range

Bypass:

The turbocharger is designed for a higher pressure ratio than normal. To prevent exceeding P_{max} at higher loads a bypass diverts part of the exhaust gases around the turbine (waste gate).

- Lower turbocharging efficiency at full load
- Higher fuel consumption at full load

Variable turbine area (VTA):

- VTA allows charge air delivery to be optimised to demand for charge air precisely, steplessly and continuously at all engine loads and speeds
- VTA minimises fuel consumption and related exhaust emissions

Aspiring to Flexibility

The VTA system consists of a nozzle ring equipped with adjustable vanes which replaces the fixed-vane nozzle rings in MAN Diesel & Turbo's standard TCA and TCR turbochargers.

Original equipment and retrofit

In this way, VTA technology can be readily retrofitted to turbochargers already in the field.

By altering the pitch of the adjustable vanes, the pressure of the exhaust gases on the turbine can be regulated and compressor output matched to the propeller's demand for power and engine's demand for charge air.

The adjustable vanes are manufactured in heat and erosion resistant alloy steel. Careful selection of fits and materials ensures operation under all conditions without sticking, especially on engines burning HFO.

To minimise thermal hysteresis and improve adjustment accuracy, each vane has a lever which is directly connected to an adjusting ring. The adjusting ring is actuated by an electric positional motor with integrated reduction gear whose development was an integral part of MAN Diesel & Turbo's VTA technology.

Control of vane pitch is fully electronic with feedback or mapped open-loop control. A comprehensive range of control signals can be used, including charge-air pressure after the compressor and exhaust gas temperature before and after the turbocharger.

Complete original equipment and retrofit packages

MAN Diesel & Turbo can thus offer comprehensive solutions for both mechanically and electronically controlled engines. For original equipment applications the precisely tailored VTA packages and all control technology complete the axial or radial TCR or TCA turbocharger.

For retrofit applications MAN Diesel & Turbo can supply packages of VTA componentry consisting of the VTA nozzle ring, the actuator and the associated control system. Since scheduled overhaul is a logical time to perform a VTA upgrade, the retrofit package can also be supplemented by other parts due for replacement.

Control unit

Integrated in engine control unit or separate control unit e.g. for retrofit

VTA

Nozzle ring with adjustable vanes

Actuator units

Two electric positioning motors

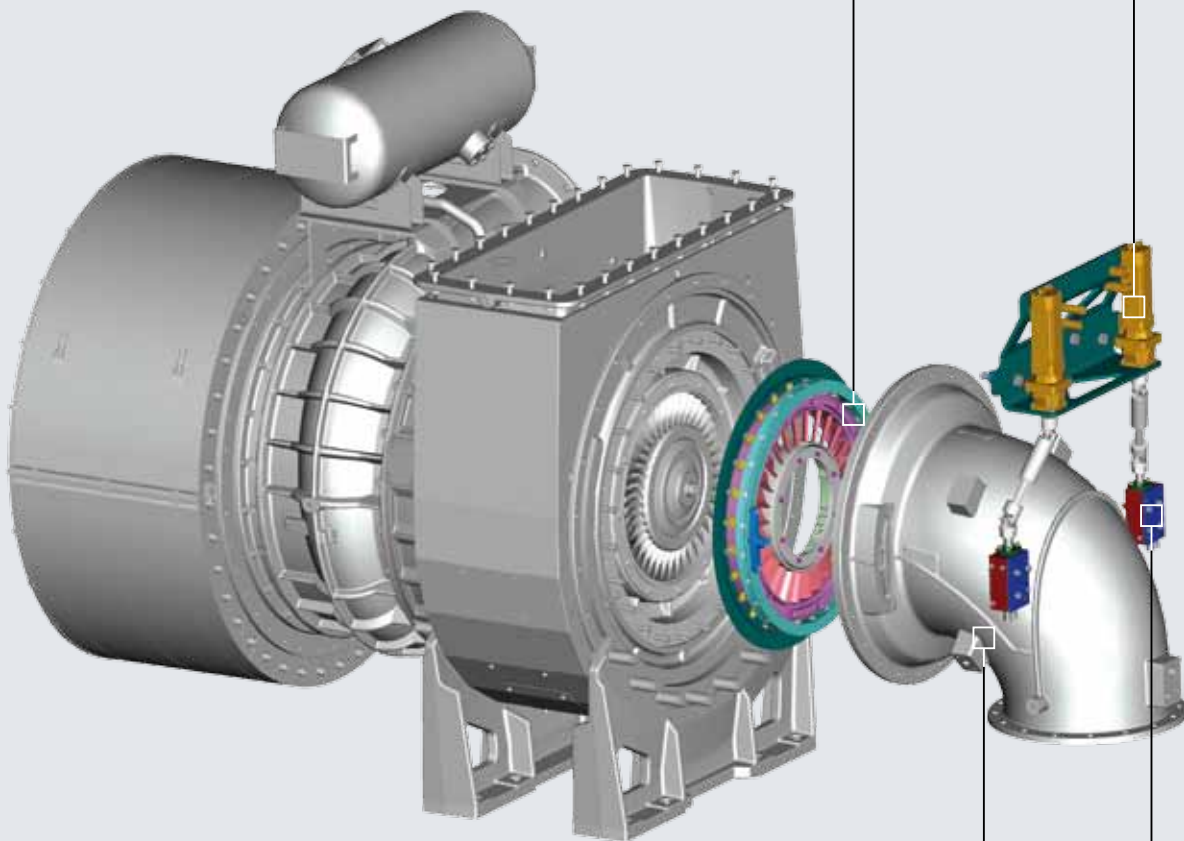

Turbine inlet casing

Reduction gear

High Savings at Low Load

A trend to efficiency

In contrast to standard fixed vane non-adjustable nozzle rings the MAN Diesel & Turbo VTA adjustable vane nozzle rings allow charge-air pressure to be increased in the engine's low and medium load operating ranges.

The result is improved combustion, to the benefit of both exhaust emissions and fuel consumption within the constraints of the NO_x: SFOC trade-off.

MAN Diesel & Turbo VTA technology allows the turbocharger efficiency trend to be adapted to a given engine load profile.

The following tables show an approximate value for the fuel savings to be expected when using VTA for a standard configuration and part-load optimisation using the example of 'slow steaming' i.e. reducing vessel speeds to reduce SFOC. The values shown already take into account the tightened IMO TIER II emissions limits for NO_x applying to all ships built after 1st January 2011.

Expected fuel savings with VTA

Part load optimised	Engine load	
	> 75%	< 75%
SFOC savings g/kWh		
MC(-C), ME-B, ME(-C) engines	0	4

Standard layout	Engine load		
	75%	50%	25%
SFOC savings g/kWh			
MC(-C), ME-B, ME(-C) engines	2	2	2

SFOC of test engine 4T50ME-X with TCA55-2 and VTA (engine load %)

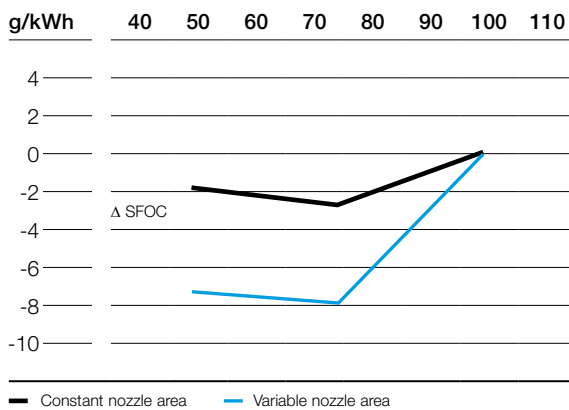

The VTA increases the turbocharger efficiency at engine part load and can be optimised to a given engine load profile (engine load in % MCR)

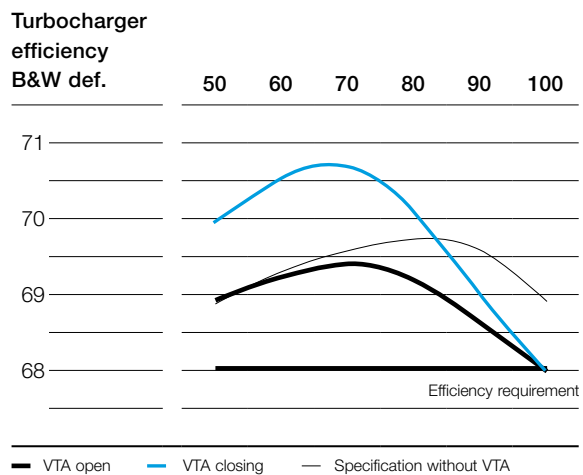



SPERANCA PER IL
MILITARE ITALIANO
LA SPERANZA DI UNO
MILITARE ITALIANO

468644
4310

19

IBU
BB

VTA – A Licence to Save Money

12,000 operating hours VTA service experience on Stena President

After thorough in-house testing, the first VTA turbo-charger went into operation on of the engines aboard the 70,000 dwt shallow draught tanker Stena President in September 2007.

The vessel has a propulsion plant featuring two MAN B&W brand six cylinder 6S46MC-C two-stroke, low speed engines.

For direct comparison under identical operating conditions one engine is fitted with a standard TCA55 turbocharger with fixed nozzle ring and the second with a TCA55 with VTA nozzle ring.

Experience during the first year of operation has exceeded the high expectations for VTA technology in terms of both its effect on engine operation and its resistance to HFO fouling.

For over 12,000 operating hours the VTA system has run 100% trouble free and delivered even higher fuel savings than expected.

Depending on engine load the reduction in SFOC on the engine fitted with VTA was as much as 4.4 g/kWh compared with the standard engine – or well over 2.5%.

For the 6S46MC-C engine rated 7,860 kW and operated at 72% load and 6,000 hours per year, the fuel savings total 150 tons of HFO per year or well over US\$ 100,000 based on a bunkering price of US\$ 700/ton for HFO of 380 cSt viscosity.

This may explain why the VTA turbocharger has already been described as “a licence to save money”!



The VTA has proven reliable operation without sticking even under severe operating conditions running on bunker with high sulphur content

<u>Bunker port</u>	<u>Viscosity @ 50°C [mm²/s]</u>	<u>Sulphur [%]</u>	<u>Alu-Si [mg/kg]</u>
Fujairah	362	3.61	29
Gibraltar	387	0.65	31
Rotterdam	349	1.28	57
Amsterdam	353	1.36	17
Beaumont	297	3.41	10



Case study

70,000 dwt tanker Stena President

Engine Type	6S46MC-C
Turbocharger	TCA55 with VTA
Engine output	7,860 kW
Average engine Load	72%
Operating hours p.a.	6,000

	Fuel savings
per kWh	4,425 g
per hour	28 l
per day	672 l
per year	150 t

Considerable fuel oil savings with VTA application (engine load %)

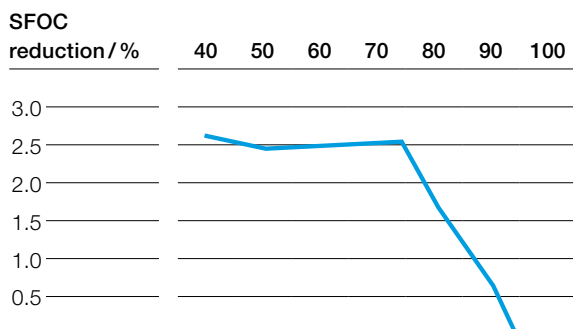

SFOC reductions on Stena President

Engine speed [rpm]	Engine load [%]	SFOC ADmax [l/h]	SFOC ADauto [l/h]	Reduction [l/h]	Reduction [%]
100	40	666	647	19	2.85
113	50	937	914	23	2.45
120	72	1,114	1,086	28	2.51
129	90	1,427	1,418	9	0.63

All data provided in this document is non-binding. This data serves informational purposes only and is especially not guaranteed in any way. Depending on the subsequent specific individual projects, the relevant data may be subject to changes and will be assessed and determined individually for each project. This will depend on the particular characteristics of each individual project, especially specific site and operational conditions - Copyright © MAN Diesel & Turbo - D23669389EN-N3 Printed in Germany GMC-AUG-06102

MAN Diesel & Turbo
86224 Augsburg, Germany
Phone +49 821 322-0
Fax +49 821 322-3382
turbochargers@mandieselturbo.com
www.mandieselturbo.com